

Figure 1

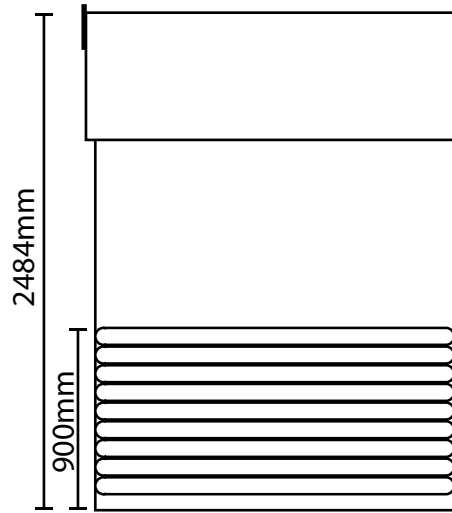

Figure 5

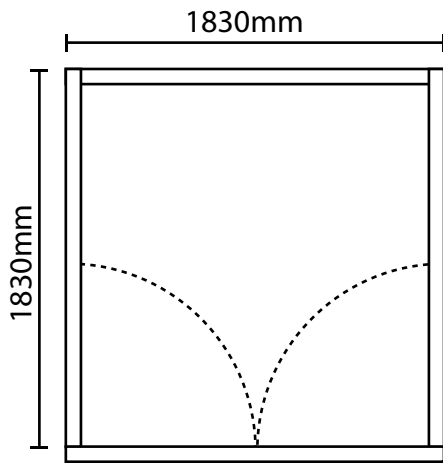

Figure 2

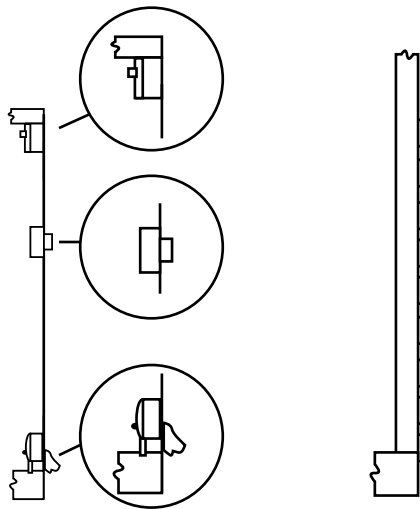

Figure 6
Section through door Shiplap detailing

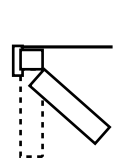

Figure 3
Door details

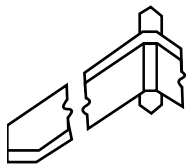

Figure 4
Fascia and ridge details

Note:
Drawings are not to scale.
Use dimensions shown only.
DO NOT SCALE FROM DRAWINGS
All dimensions are in millimeters

Beach Huts on Hove Esplanade



The Beach Huts of Hove

This leaflet explains to owners of beach huts on Hove Esplanade the terms and conditions of their licence and draws attention to the correct way to repair or replace a beach hut.

Hove Esplanade

To many people, the main attraction of Hove is its beach and the enjoyment of walking along a wide elegant Esplanade with its fine views and long rows of colourful beach huts. The beach huts are an asset to both their owners and to residents of the whole City.

The Council is concerned that the attractive image of the seafront should be maintained. The Council will, resources permitting, continue to maintain and improve the Esplanade and the way in which the owners of beach huts maintain or replace their beach huts will have a significant impact on the future appearance of the Esplanade.

The Maintenance of Beach Huts

One reason why the Hove beach huts are admired is that they are largely the same except for their colourful front doors and it is vital to the character of the seafront that the uniformity is not lost.

Beach hut owners are required, within the terms and conditions of their licences, to repair or replace in accordance with certain details. These details are as explained below.

Repairs

If a hut is damaged in any way or requires major repair, then the repairs must match, in every way, the original design shown in this leaflet.

Damage to doors should not be repaired by covering the door in boarding. The doors should be repaired properly or replaced completely. If a door is replaced completely the design in (fig. 1) must be followed. Other major repairs should also be in accordance with the approved drawings and particular attention must be given to the use of materials, for example fibreglass and, felt are not permitted.

Doors to consist of 100 x 50mm S.W. framing rebated 16mm to accept 10mm thickness exterior grade plywood panelling/tongue and groove and 100 x 38mm mid rail and bottom rail. All joints to be morticed and tenoned. The bottom rail should be 40mm above the bottom of the door.

Each door to be hung on 2 substantial stainless steel hinges and they must open inwards.

There should be one bolt top and bottom on one of the doors and there should be at least two hasps for the padlocks which should be bolted (not screwed) on to the other.

The following specifications must be used in carrying out general repairs:

- Wall and roof panels: 10mm external quality plywood
- Boarded lower plinth: 19mm shiplap softwood boarding
- Floor: sawn treated timber boards
- Bargeboard: 150 x 25mm
- Ridge: 75 x 19mm

Painting

The outside of the beach hut must be painted as often as necessary, but at least once every year.

The roof and the upper sides of the hut must be painted in paint no. **BS 4800 14 C35 Gloss**. If the traditional appearance of the beach hut is to be maintained, then it is important that the plinth and lower sides must be painted in paint no. **BS 4800 04 D45 Gloss**. The doors can be any single solid colour or vertically striped in multiple colours.

Good preparation is essential if the top coat of paint is to adhere well in coastal conditions and the burning off of previous coats may be necessary. An aluminium primer should be used followed by two undercoats and one gloss coat.

Complete Hut Replacement

When the condition of a hut is such that it becomes uneconomic to repair or otherwise as desired, it can be replaced with a hut and design of exactly as that shown in this leaflet but to the following dimensions:

1.83m (6ft) wide x 1.83m (6ft) deep with ridge roof height of 2.46m (8'1"). Variations in design of dimensions are not permitted and if you wish to rebuild your hut then a copy of this leaflet should be given to your carpenter/joiner. The strength of construction of the hut can be improved to suit, as long as the external appearance is not altered.

Council Enforcement

The Council will, with the aim of enforcing the terms of the licence, make an annual inspection of all beach huts early in the year. If an owner of a beach hut fails to carry out necessary repairs or painting, or otherwise fails to comply with the terms of the licence the Council has the right to terminate the licence, require the hut to be removed and, if it is not removed by the owner, to remove the hut at the owners expense.