

NOTES

GENERAL

1. ALL DIMENSIONS ARE IN MILLIMETRES UNLESS NOTED OTHERWISE.
2. ALL LEVELS RELATE TO ORDNANCE DATUM UNLESS NOTED OTHERWISE.
3. DO NOT SCALE FROM THIS DRAWING. USE FIGURED DIMENSIONS ONLY.
4. ANY DISCREPANCIES TO BE REPORTED IMMEDIATELY TO THE ENGINEER.
5. THIS DRAWING TO BE READ IN CONJUNCTION WITH ALL RELEVANT ARCHITECTS, SUBCONTRACTORS AND SPECIALISTS DRAWINGS AND SPECIFICATIONS.
6. THIS DRAWING IS COPYRIGHT © PROPERTY OF SHEAR DESIGN LIMITED.

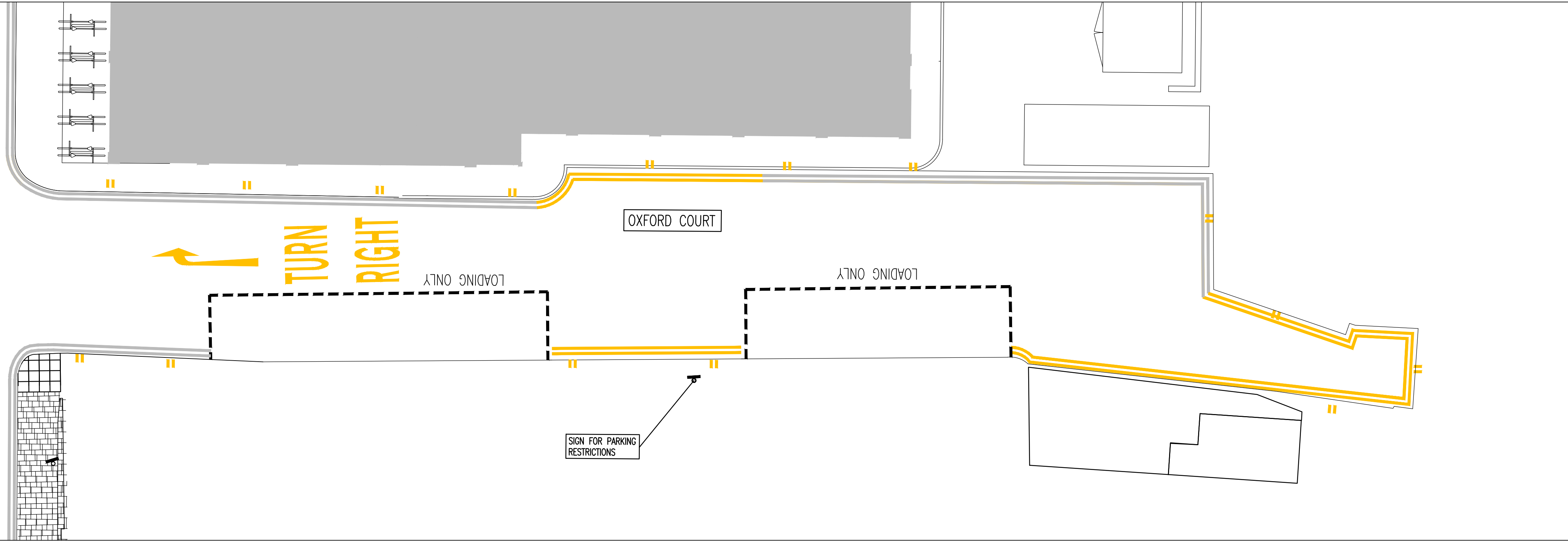
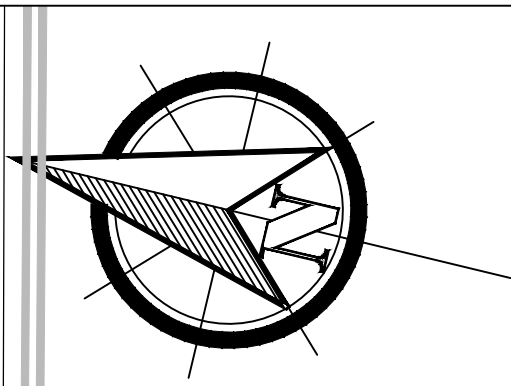
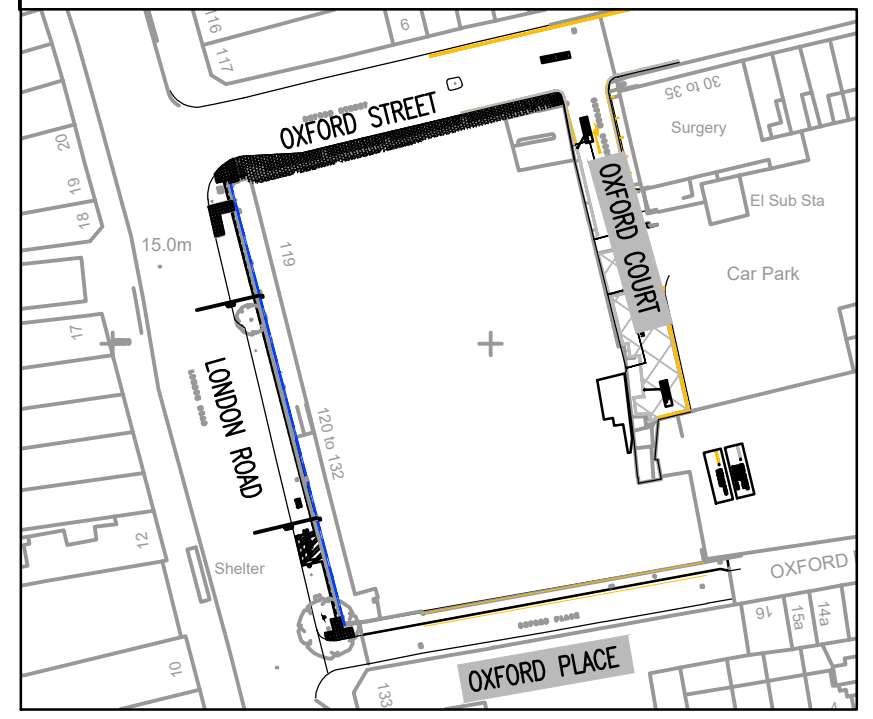

PROPOSED TRAFFIC REGULATION ORDER REQUIREMENTS

REV	DATE	DESCRIPTION	BY	CHK
F	16.12.20	AMENDED TO B&H COMMENTS OF 15.12.20	TZ	SJM
E	11.12.20	AMENDED TO B&H COMMENTS OF 18.11.20 AMENDMENT SHOWN IN CLOUD	TZ	SJM
D	17.11.20	AMENDED TO B&H COMMENTS OF 16.10.20	TZ	SJM
C	04.10.20	AMENDED TO HIGHWAY MEETING COMMENTS OF 02.10.20	TZ	SJM
B	22.09.20	EXISTING LOADING BAY REMOVED FROM PROPOSED WINDOW	JE	SJM
A	22.09.20	HATCHED BOXES REPLACED WITH LOADING BAYS	JE	SJM

CLIENT: CURLEW OPPORTUNITIES

PROJECT: 119 LONDON ROAD
BRIGHTON

TITLE: TRAFFIC REGULATION ORDER
REQUIREMENTS



DRAWN: JE | CHECKED: SM | DATE: 26.04.2019 | SCALE: 1:100 @ A1

STATUS KEY: I = INFORMATION P = PRELIMINARY A = APPROVAL CO = CONTRACT
T = TENDER C = CONSTRUCTION AB = AS-BUILT

STATUS: A | DRAWING NUMBER: 17059-206 | REVISION: F